

REV.	ECN.NO.	MODIFY.CONTENT	DATE
A		NEW	2013/10/31

冲压技术要求:

1. 材质: 不锈钢SUS304-3/4H, T=0.10±0.005;
- ▼2. 端子锡脚焊接面和接触面不可有毛边, 其他部位毛边最大0.03mm;
3. 扭曲: 45°/1000mm, 拱形 5mm/1000mm;
4. 标示有"▼"符号的为重点控制和检验尺寸;
5. 未标注之R MAX R0.13;
6. 预断45°来回两次即可折断, 电镀须满足48小时盐雾测试;
7. 寿命测试>200次, 产品弹力要求在60gf~80gf之间
8. 镀底50u"min, 焊接区域镀金, 接触区域镀金3U"MIN
9. 每盘接头不可超过三个, 接头部位需标示以利识别;
10. 产品采用载带包装, 每盘2K;

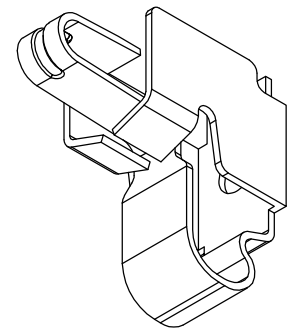

3D图

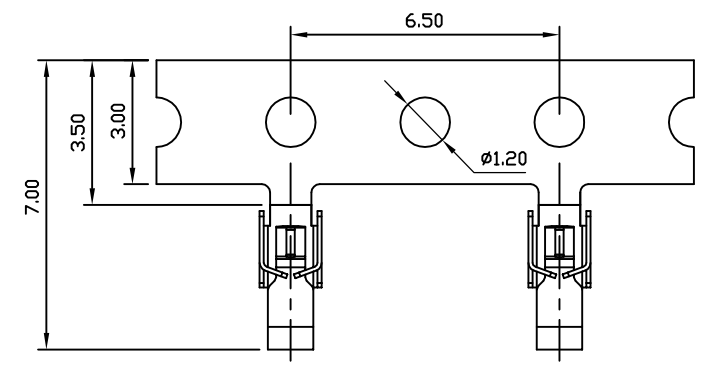
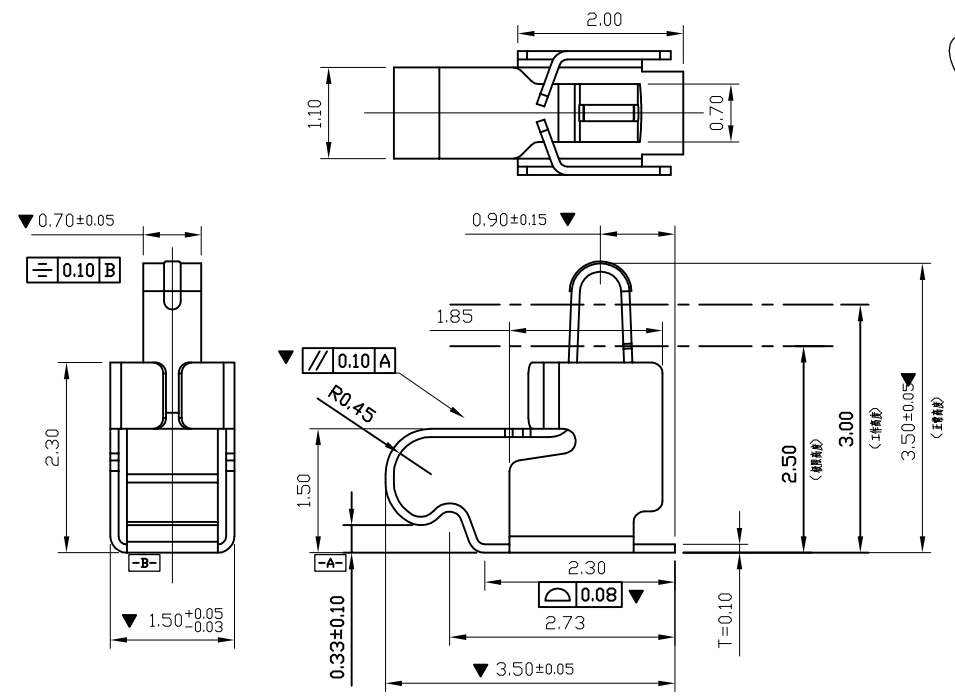

料带示意图

比例: 1/2

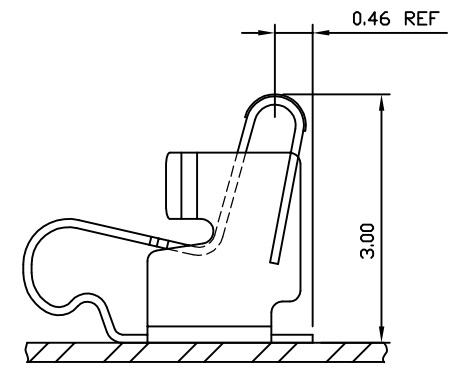
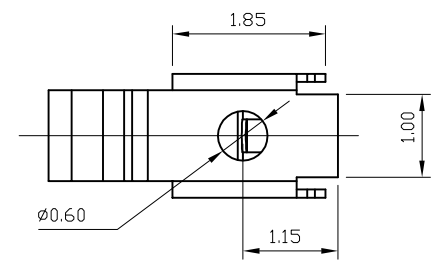

正常工作高度 H=3.00

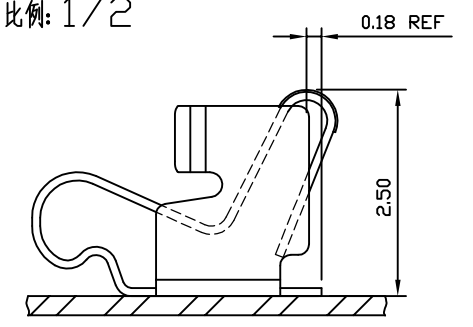

最大极限高度 H=2.50

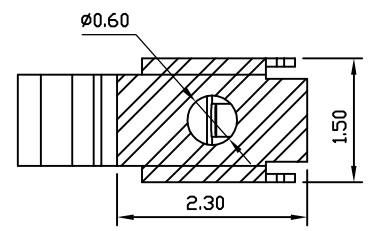

焊盘尺寸
尺寸公差 ±0.05

GENERAL TOLERANCE		DWG NO.	JYSA0528-012	APPD:	WIND	Scale	1:1
X.±0.20	x.'±2.0'	Title	天线弹片 L3.5*W1.5*H3.5	CHKD:		UNIT	mm
.X±0.10	.x'±1.0'			DR:			
.XX±0.05	.xx'±0.5'	Part NO.	JYS-TP350-013	Date	2013/10/31		
.XXX±0.03	.xxx'±0.5'						
SHEET	1/1						



杰宇森电子有限公司
JIE YU SEN ELECTRONIC CO., LTD.